

THIRD ANGLE PROJECTION

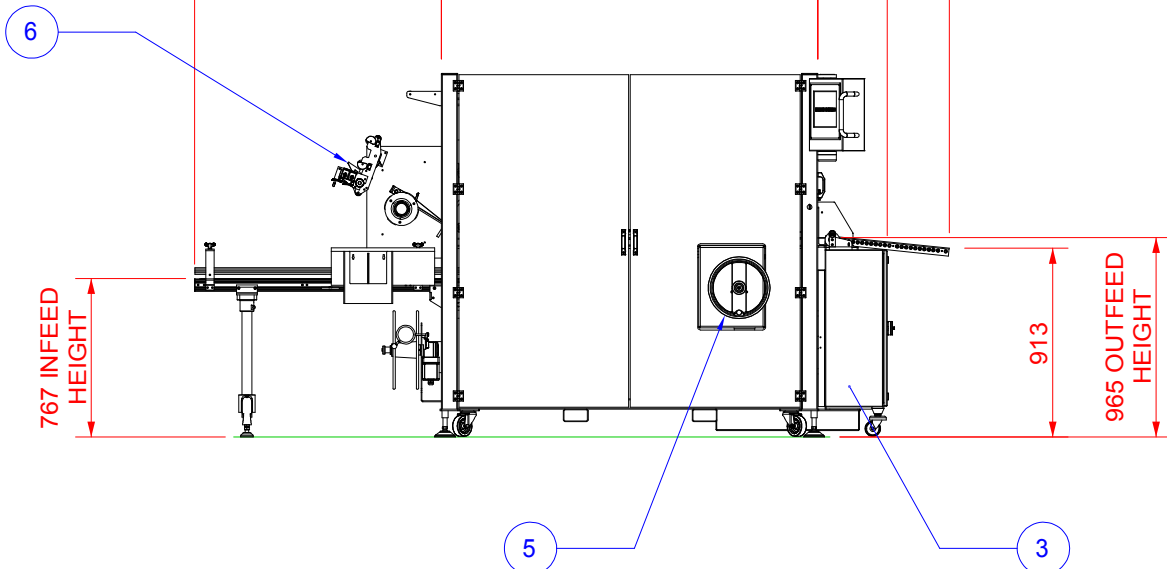

- 1 TM100FF
- 2 1.5m x 300mm INFEED CONVEYOR
- 3 ELECTRICAL CABINET
- 4 MACHINE CONTROL HMI (ADJUSTABLE)
- 5 HANDWHEEL
- 6 FILM SLITTER (OPTIONAL EXTRA)
- 7 GRAVITY ROLLER OUTFEED (OPTIONAL EXTRA)

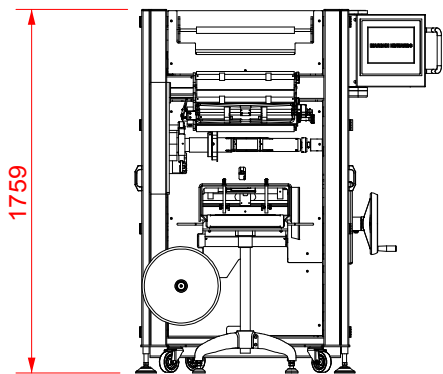
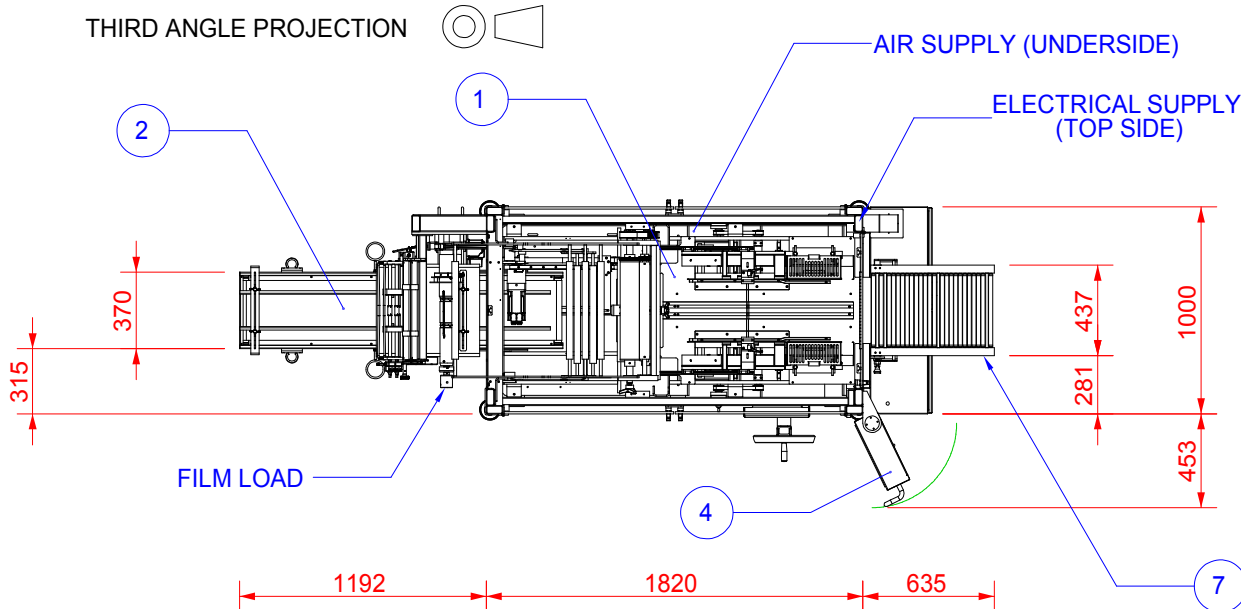

ISSUE	DATE	EDI	APPROVED BY (PRINT NAME)	APPROVED BY (SIGNATURE)	DATE	

	TM100FF				DATE	30/10/07
	SIM TO		SCALE	1:25	Wt	Kg
	DRN BY				MAB	
	(01202) 861200			DRG No	FP2332	