

THIRD ANGLE PROJECTION

- 1 - 1.5M x 0.3M INFEED CONVEYOR
- 2 - TUNNEL GUARD
- 3 - BX125LH/7 MACHINE
- 4 - PRODUCT TRANSFER
- 5 - RH HANDWHEEL
- 6 - RH FILM LOADING
- 7 - ELECTRICAL BOX
- 8 - CONTROL PANEL WITH TOUCH SCREEN
- 9 - ELECTRICAL CONNECTION POINT
- 10 - PNEUMATIC CONNECTION POINT

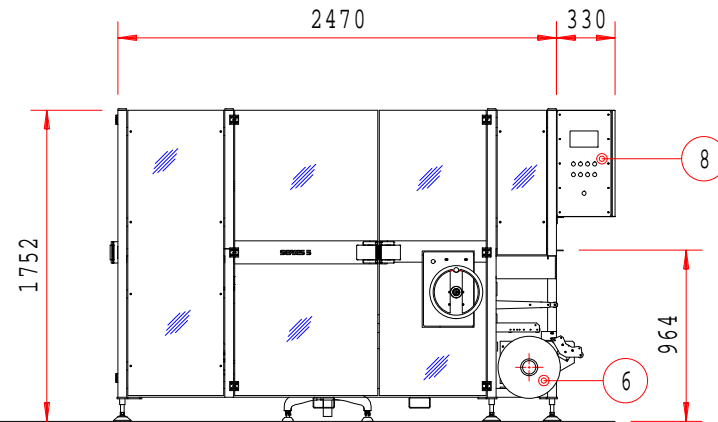
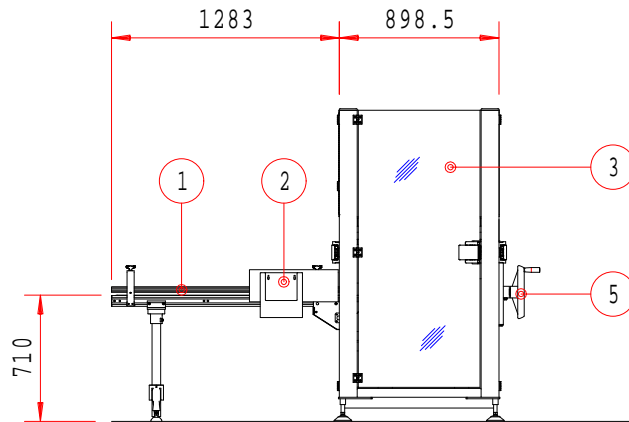
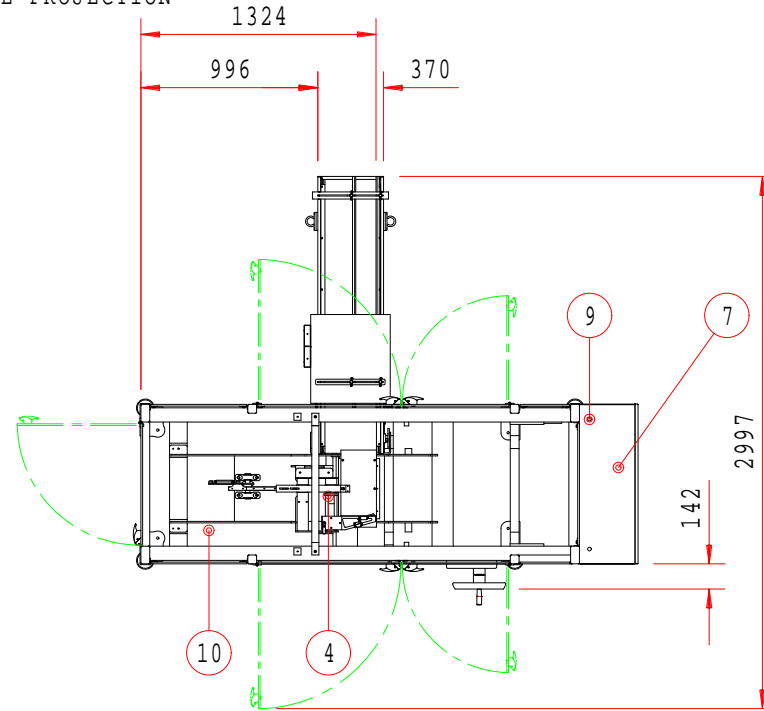

ALL DIMENSIONS ARE APPROXIMATE

○		
○		
○		
○		
○		
ISSUE	DATE	E.D.I.

APPROVED BY (PRINT NAME)	APPROVED BY (SIGNATURE)	DATE

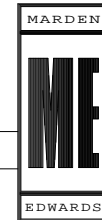

S5 BX125LH-7 200 DECK			
SIM TO	-	DRN	DW
SCALE	1:30	DATE	12/01/2010
M/C NO			
☎ (01202) 861200		DRG.NO.	FP2576